



Silicon Microchannel Cooling

**.. and related
microfluidic and microcooling
topics**

**Han Gardeniers
MESA+ Research Institute -University of Twente, NL**

20th January 2003

Outline

- short overview MESA
- short overview BIOS / Lab-on-a-Chip
- buried microchannels:
 - micromachining process
 - silicon nitride and polysilicon
 - applications: pipette for mechanical DNA study
- cryogenic microcooler project overview





MESA+ Research Institute Organisational Overview

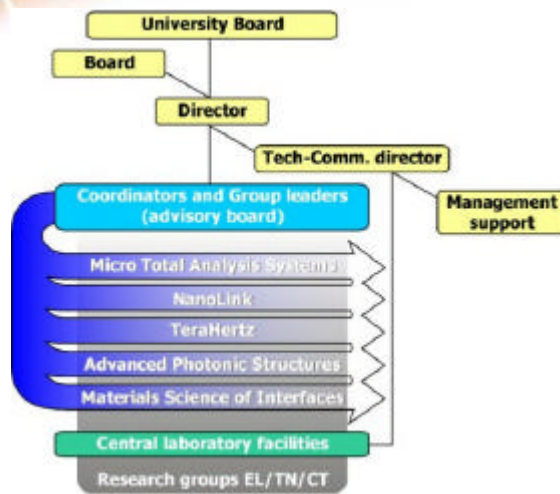

MESA+ Research Groups

Chem. Eng.:	Chemical Analysis (CA) Inorganic Materials Science (IMS) Materials Science and Technology of Polymers (MTP) Supra Molecular Chemistry and Technology (SMCT)
Electr. Eng.:	Biosensors / Lab-on-a-Chip (BIOS) Semiconductor Components (SC) Computer Architecture, Design & Test for Embedded Systems (CADTES) Integrated Circuit Design (ICD) Systems and Materials for Information Storage (SMI)* Lightwave Devices (LDG)* Transducers Science and Technology (TST)
Appl. Phys.:	Biophysical Techniques (BFT) Computational Materials Science (CMS) Systems and Materials for Information Storage (SMI)* Lightwave Devices (LDG)* Low Temperature Physics (LT) Optical Techniques (OT) Solid State Physics (VSF) Complex Photonic Systems (COPS)
Appl. Math.:	Applied Analysis and Mathematical Physics (AAMP)



Micro and nanofluidic devices for chemical and biomedical applications

**Current research
BIOS Lab-on-a-Chip group**

Han Gardeniers

MESA+ Research Institute - University of Twente, NL
(also with Miconit Microfluidics B.V.)

1st November 2002

Development of μ TAS/LOC concept



1970



1980



1990



MESA+

2000 and beyond: Lab-on-a-Chip

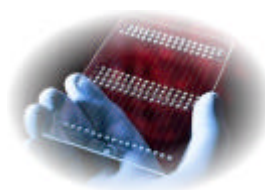
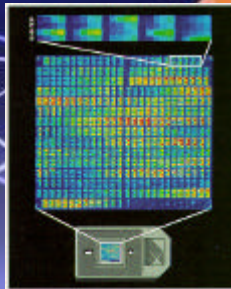

MESA+

Lab-on-a-Chip: motivation

General reasons for miniaturisation:

- Reduced weight (portable)
- Reduced size (implantable, integratable)
- Reduced price (batch fabrication, disposable)
- Reduced consumption of chemicals (expensive or limited source)
- Reduced energy consumption
- Reduced production of waste (toxic products)
- Reduced flow (accurate dosing)
- Increased heat exchange
- Fast mass transport
- Integration of sensors
- Parallelisation
- Automation



Micro Flow Injection Analysis System for Ammonia determination

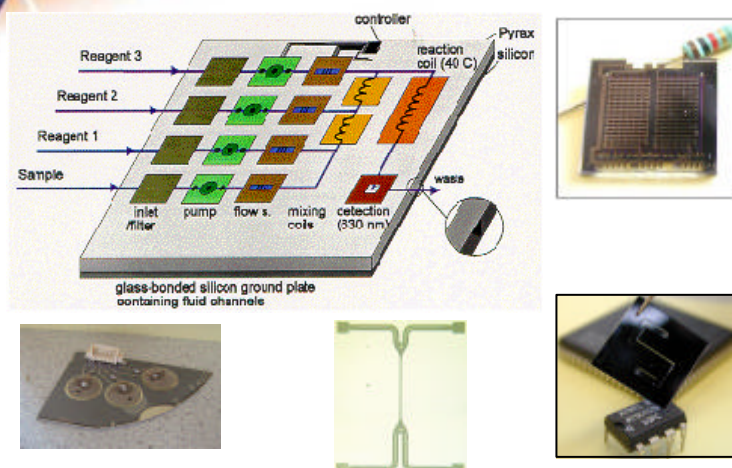

from: Ph.D. thesis Theo Veenstra



Measurements modular system

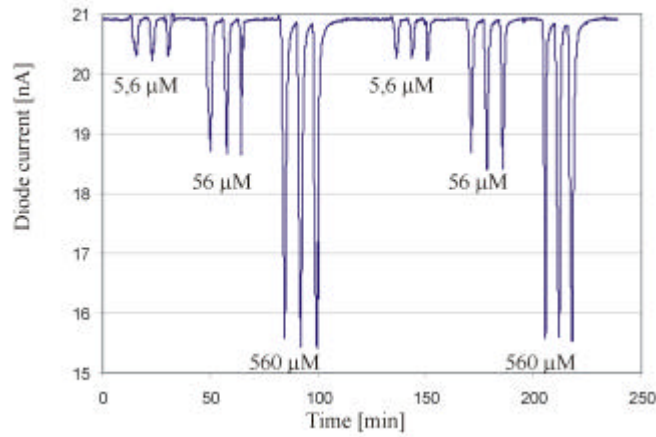

R.M. Tiggelaar et al., Sens. & Act. B in press



Hydrodynamic chromatography chip

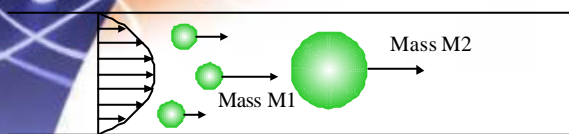

Separation is enhanced by smaller channel height

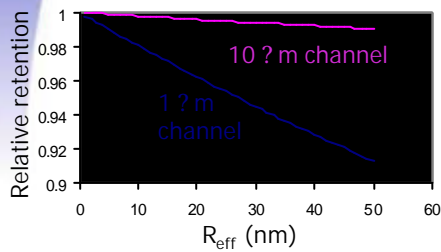

from: Ph.D. thesis Marko Blom

Anal. Chem. 74, 2002, p. 3470-3475, Sens. & Act. B 82 (2002) pp. 111-116



Separation of 26, 44, 110, 180 nm fluorescent polystyrene particles and a marker



Silicon micromachined hollow microneedles for transdermal liquid transport

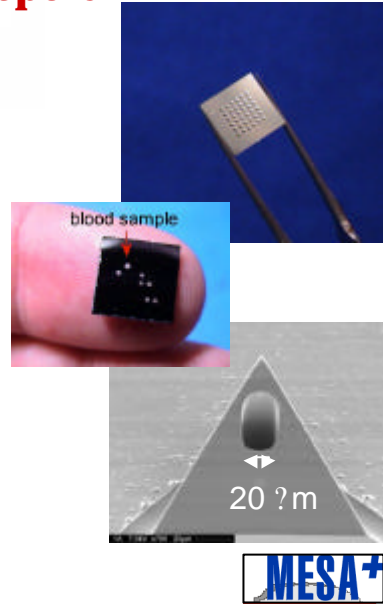
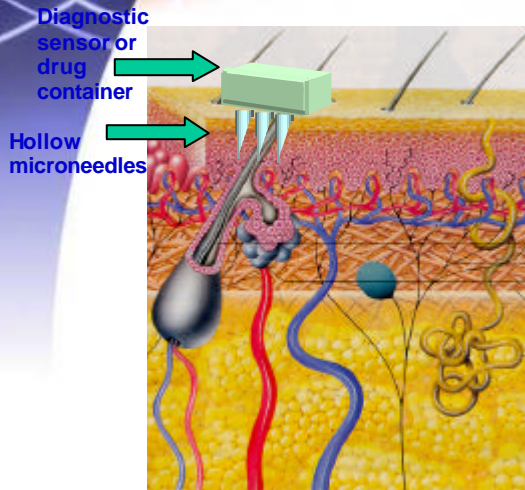

MESA+

Fabrication process out-of-plane needles

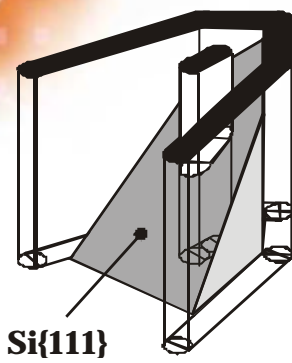

DRIE etch

KOH etch

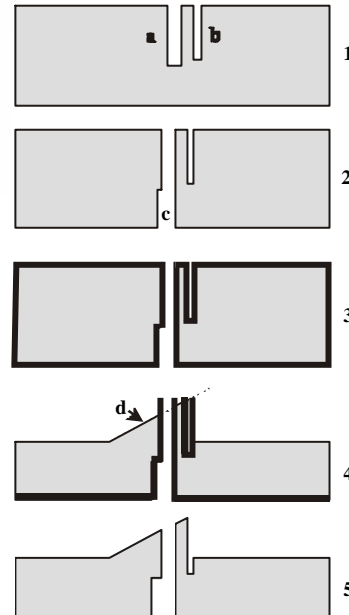
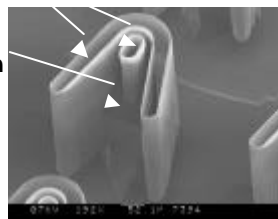

MESA+

Proc. MEMS 2002, pp. 141-146; submitted J. MEMS

Resulting microneedles

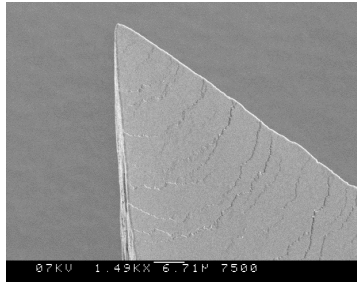
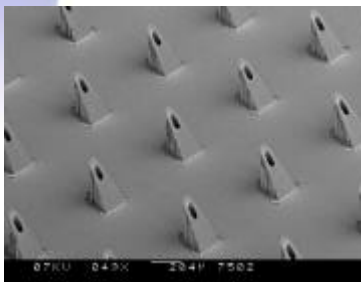
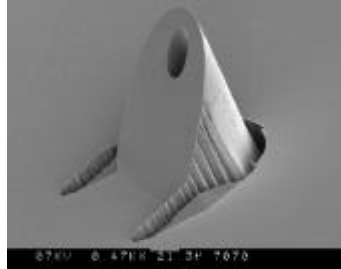
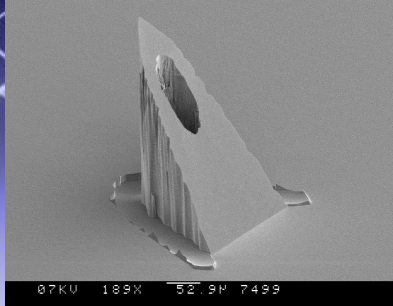

Application of Sodium Diclofenac to rats

Drug plasma concentrations obtained after 6-hr applications of increasing number of microneedles

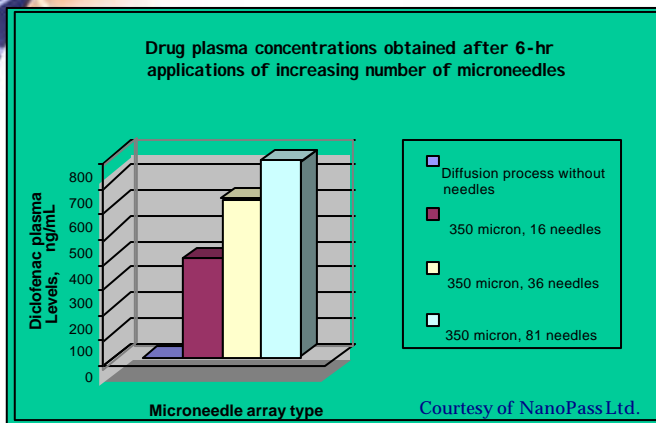

Courtesy of NanoPass Ltd.



Microsystem for lithium therapy monitoring



glass chip for capillary electrophoresis with end-column integrated conductivity detection

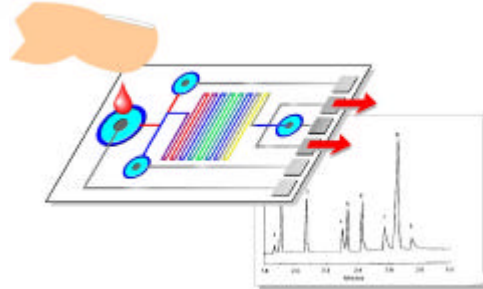

close-up of platinum electrodes integrated at end of electrophoresis microchannel

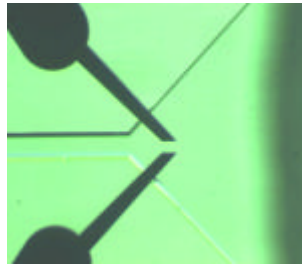

work of: Elwin Vrouwe and Regina Lutttge



Silicon microneedles + CE chip

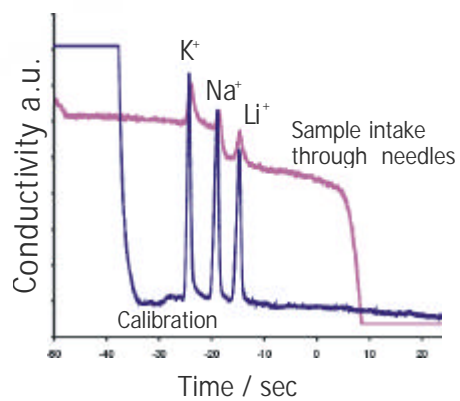
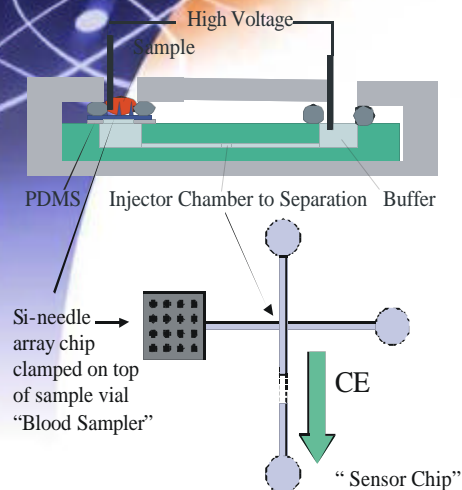

Work of: Regina Lutttge



Buried microchannels in silicon

SEE PRESENTATION PART 1

Mechanical measurements on DNA

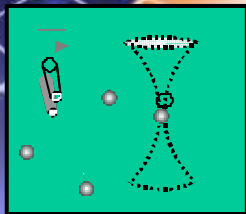

Capture bead

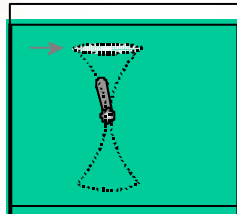

Place bead on pipette

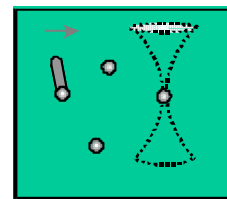

Capture bead

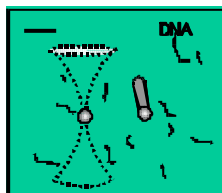

Capture DNA

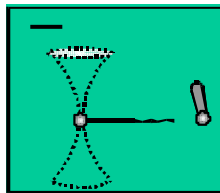

Stretch DNA



Stretching of λ -phage DNA

Two beads, one gripped by a micromachined pipette and the other by optical tweezers, with a DNA molecule (not observable) in between

(a) no force applied

(b) 30pN force applied

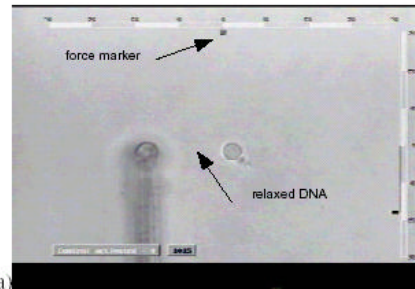
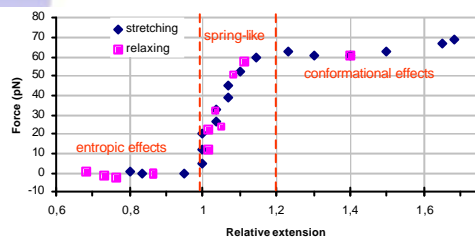

(a)

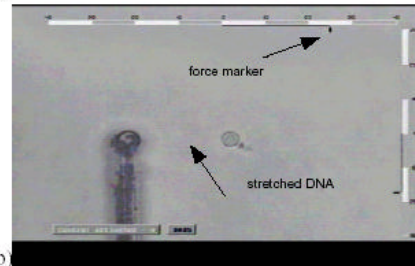

(b)

MESA+

Miniaturized cryocooler

Johannes Burger, Han van Egmond, Harry Holland,
Han Gardeniers, Marcel ter Brake and Miko Elwenspoek

MESA+ Research Institute, University of Twente, The Netherlands

Financial support:
Dutch Foundation for Technological Research (STW)
Project TTN.3100 "Microcooling"

MESA+

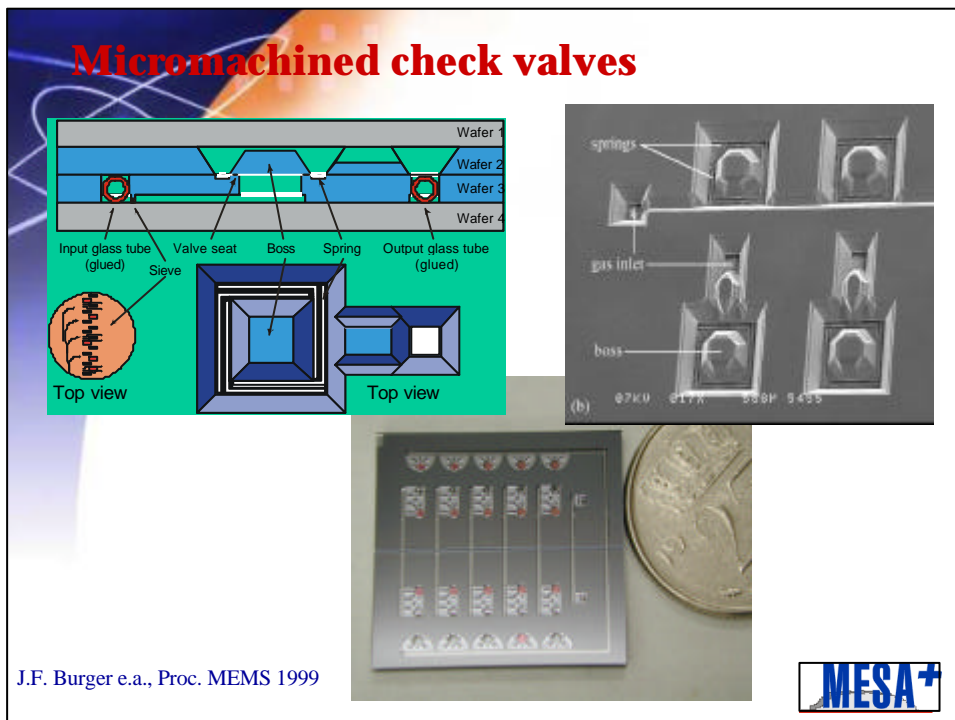
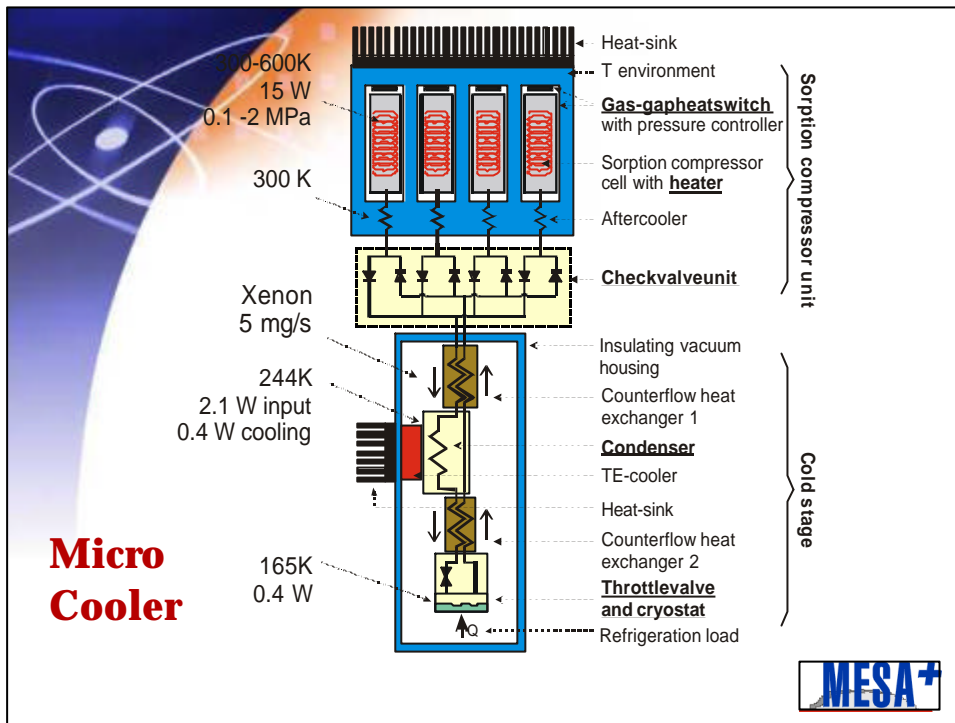

Cold stage structures on 4-inch silicon wafer

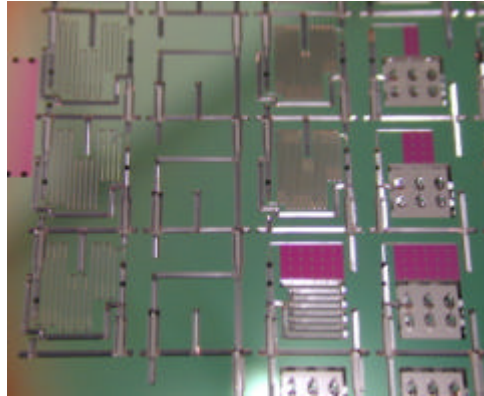
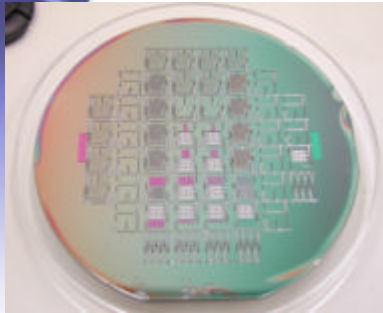

J.F. Burger e.a., Proc. MEMS 2001



Micro cold stage

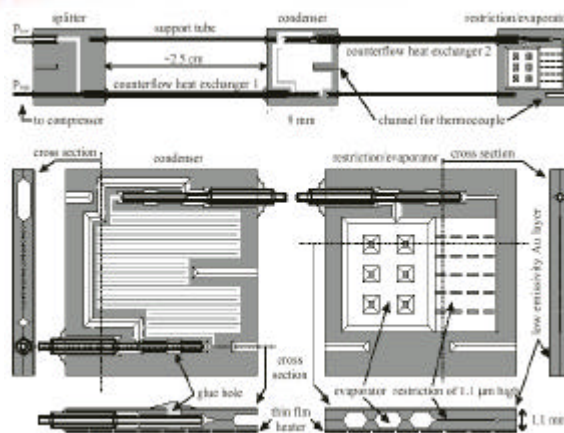

Micro cold stage fabrication

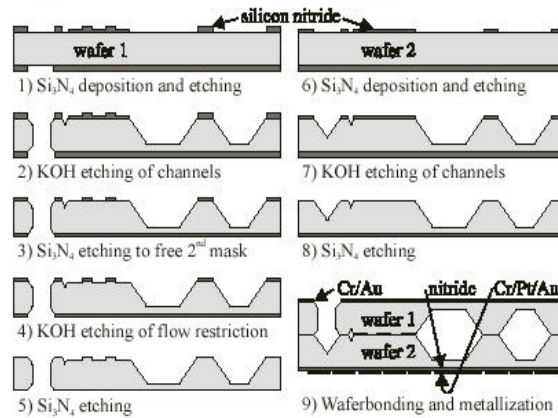

MESA+

Integrated cold stage

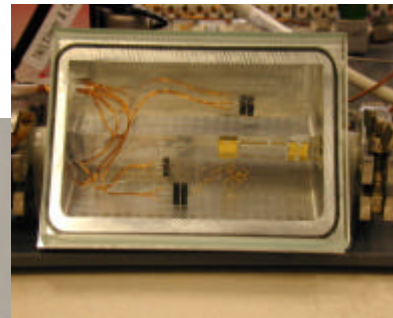
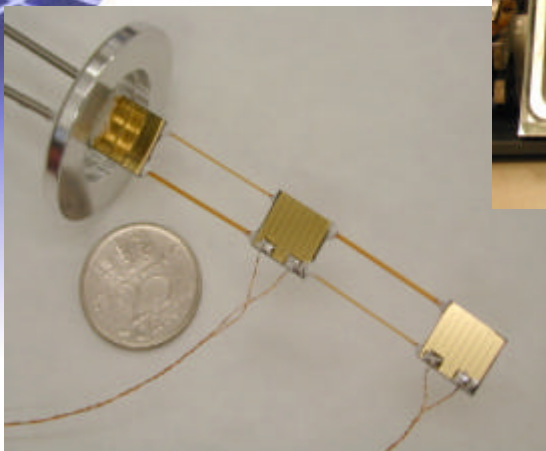

J.F. Burger e.a.,
MEMS 2001

MESA+

Glued capillary-to-chip connection

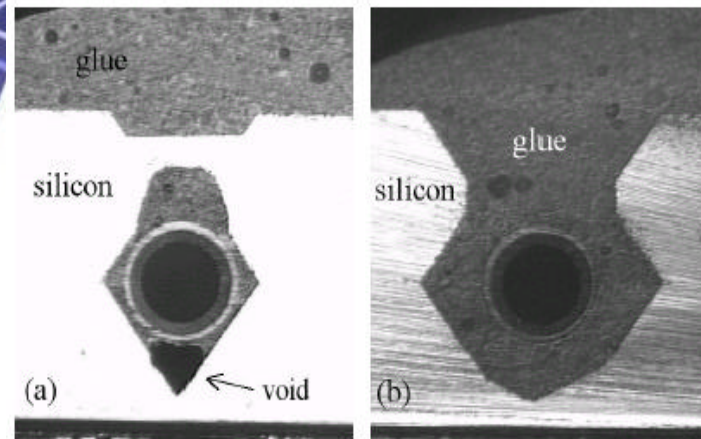

MESA+

Compressor design

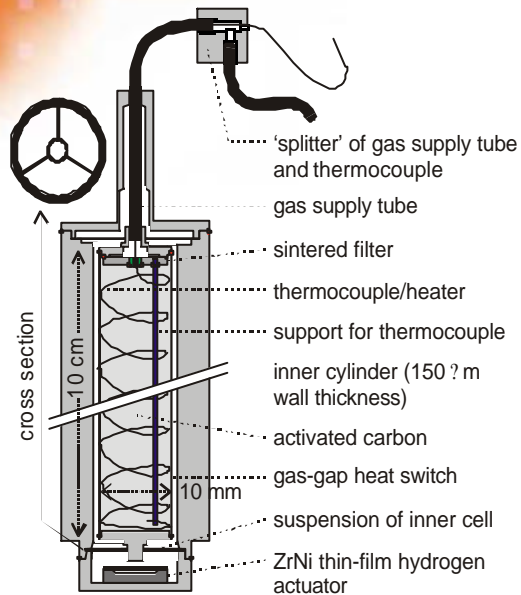

MESA+

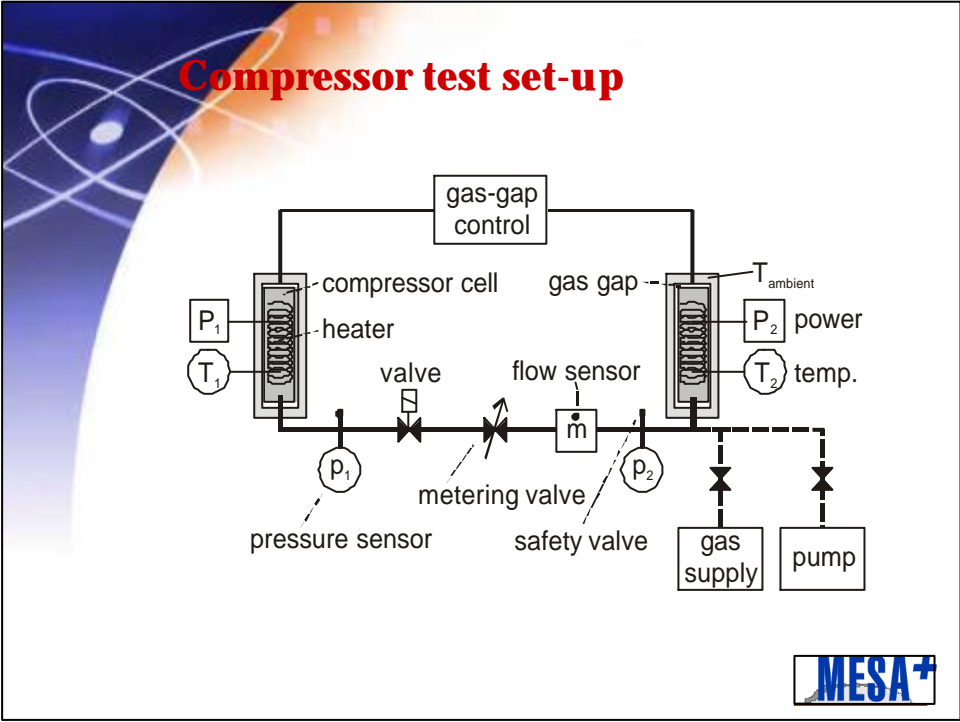
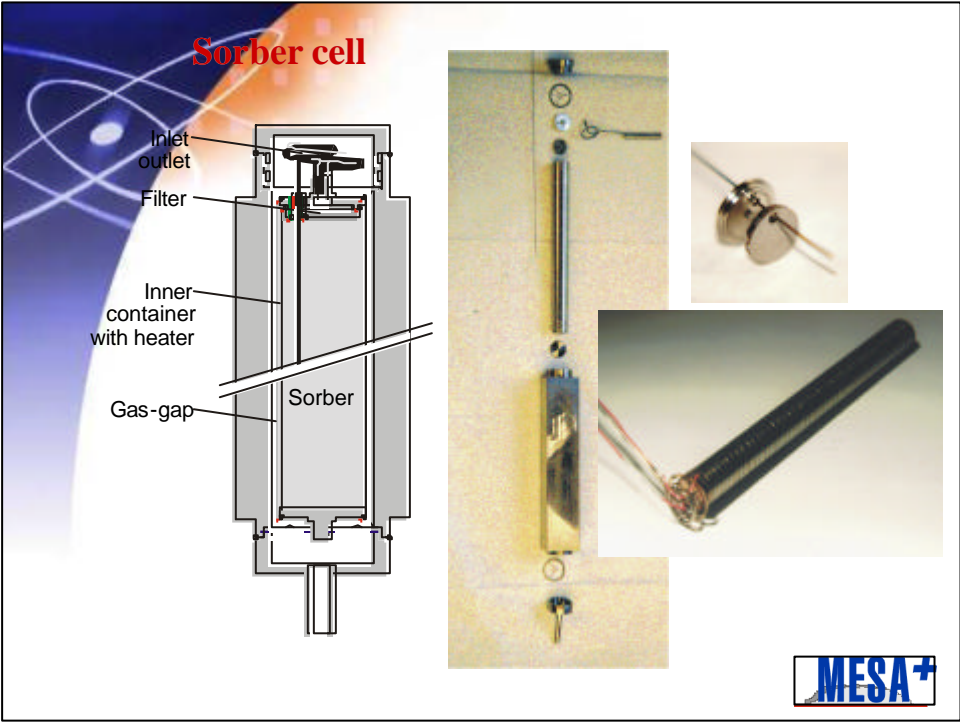

Compressor flow test

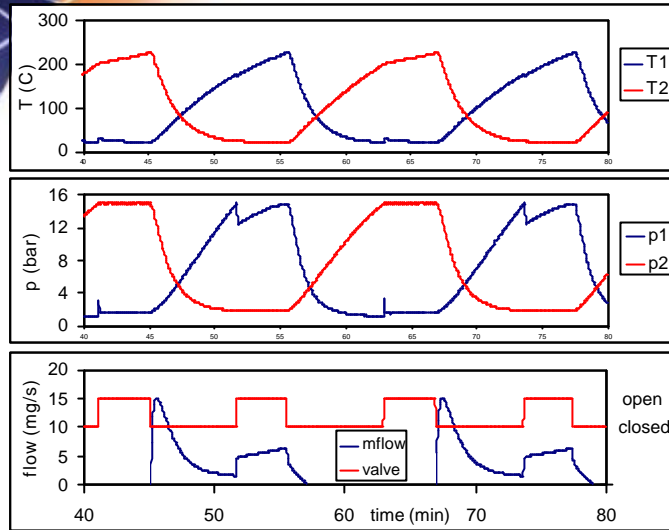

MESA+

Thermal switches: mechanical example

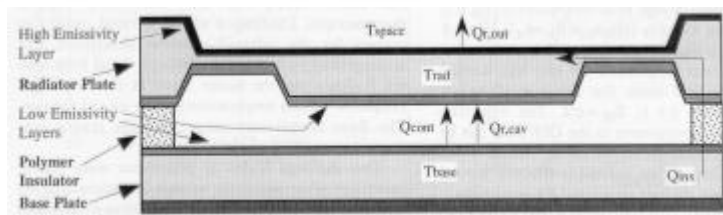

T. Slater e.a. Techn. Digest Transducers 95, Stockholm

MESA+

Gas gap heat switch with hydrogen (1)

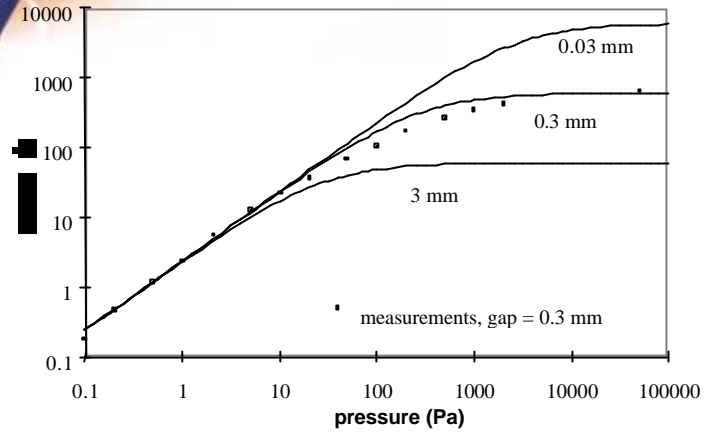

J.F. Burger e.a., Thermodynamic considerations on a microminiature sorption cooler, Cryocoolers 10, Kluwer Academic / Plenum Press, New York, 1999, p. 553



Gas gap heat switch with hydrogen (2)

Requirements heat switch:

- low pressure < 0.5 Pa
- ON-OFF pressure ratio $> 50^*$
- switching times < 30 sec
- actuation power < 0.2 W
- lifetime $> 10^6$ cycles

*limiting ON-OFF ratio ? 150 (mm) / gap width = 500 for gap of 300 ?m

J.F. Burger e.a., Thermodynamic considerations on a microminiature sorption cooler, Cryocoolers 10, Kluwer Academic / Plenum Press, New York, 1999, p. 553



Metal hydrides

Van 't Hoff plots for several metal hydrides

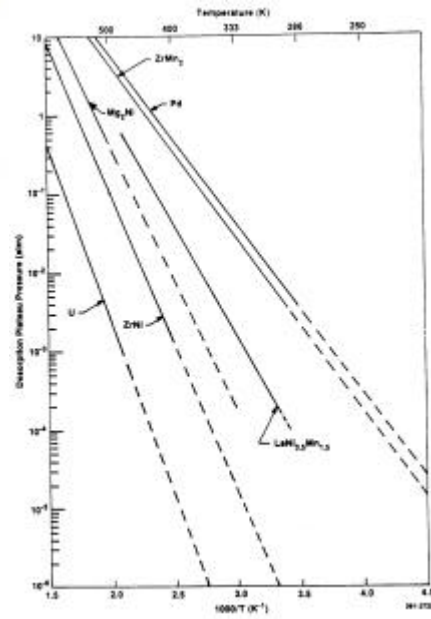

Metal hydrides: phase transition

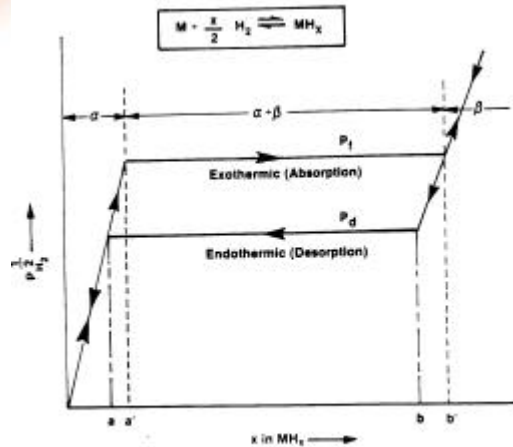

Absorption and desorption lines for one isotherm



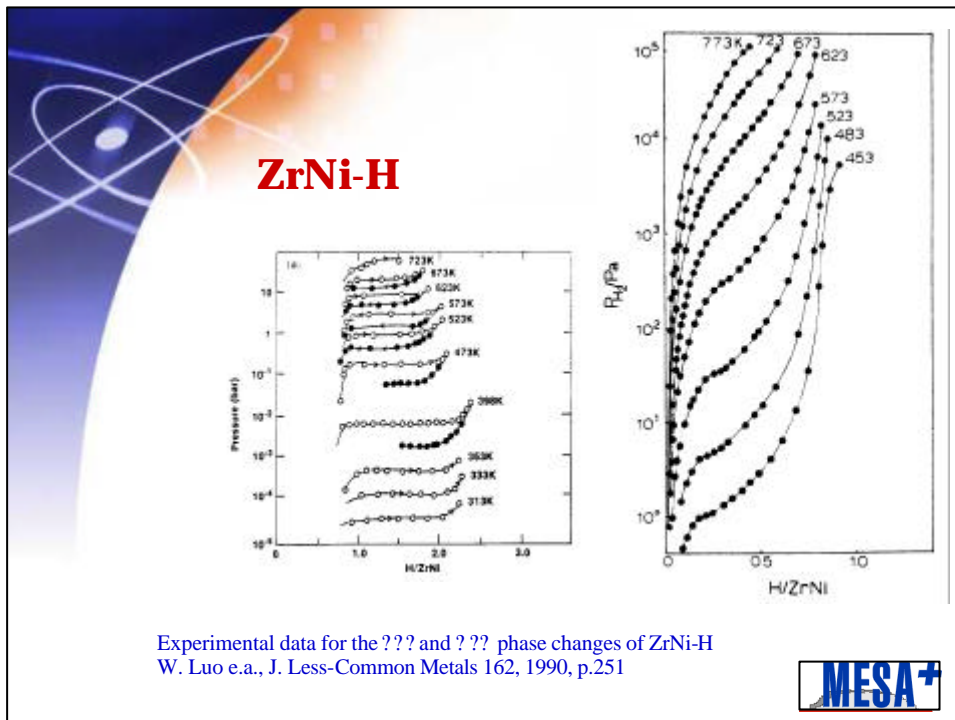

ZrNi films for reversible H_2 pressure actuation

Why films?

- Sputtered films offer possibilities for integration with e.g. heater elements
- Passivation with Pd film possible (bulk ZrNi is very sensitive to oxygen)
- Thin films offer faster hydrogen pressure switching

ZrNi films: Experimental results (1)

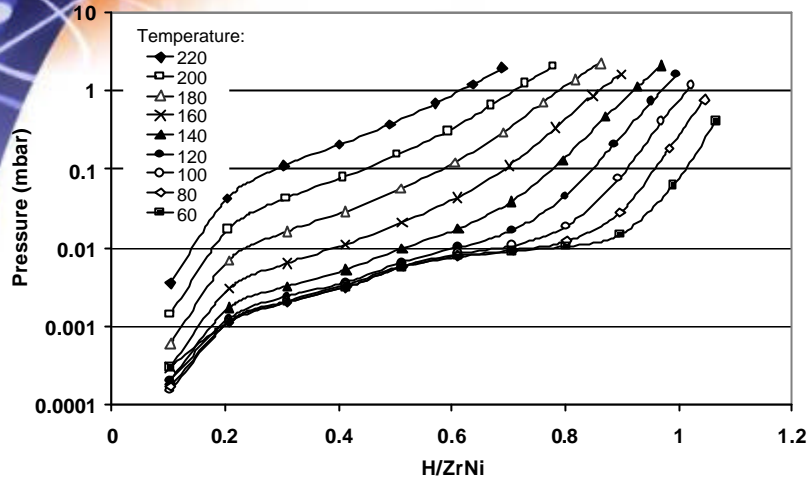

Gardeniers e.a., Proc. AKTUATOR 2000



ZrNi films: Experimental results (2)

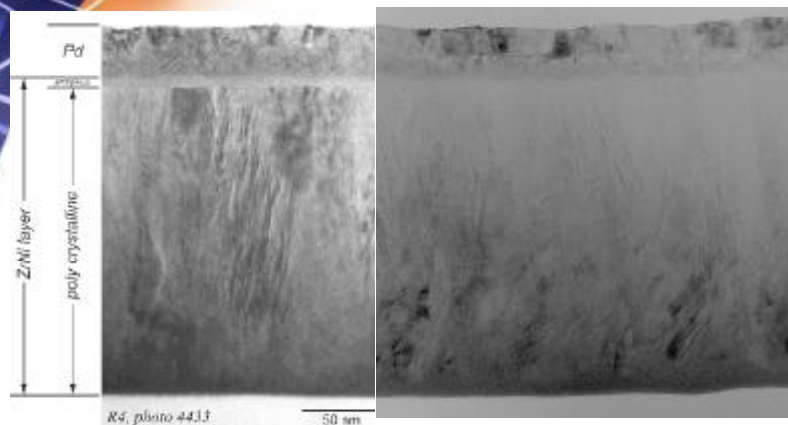

TEM pictures of ZrNi-Pd film before (left) and after (right) several thousands of absorption cycles

Gardeniers e.a., Proc. AKTUATOR 2000



ZrNi films: Experimental results (3)

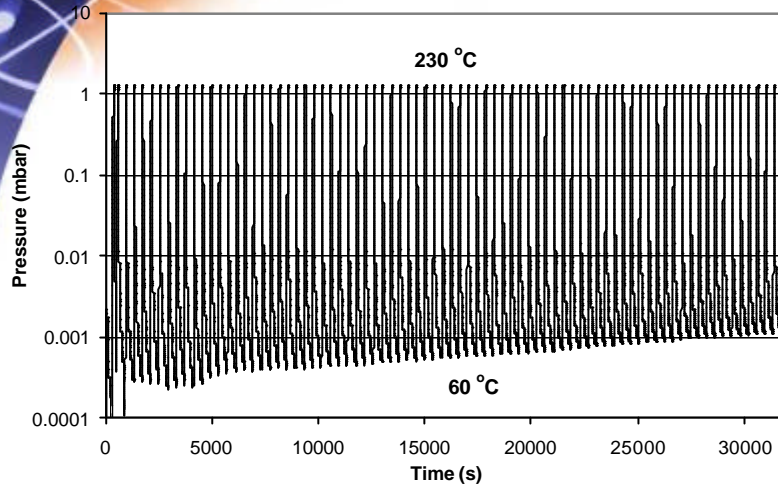

Obtained pressure swing: 0.03 Pa - 125 Pa

Gardeniers e.a., Proc. AKTUATOR 2000



ZrNi films: Experimental results (4)

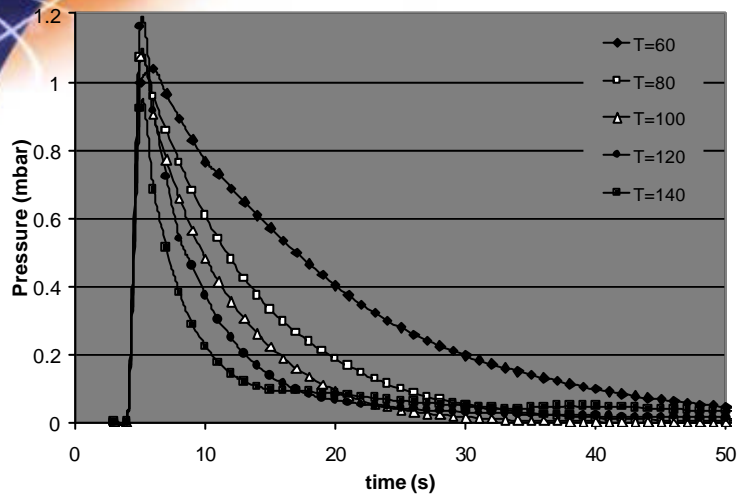

Obtained switching times: less than 60 secs.

Gardeniers e.a., Proc. AKTUATOR 2000





Acknowledgements

- Stichting Technische Wetenschappen (Dutch Technology Foundation) & NanoPass Ltd.
- MESA+ clean room staff for technical support

